

## Financial Engineering as Alchemy



Peter Rivera  
March 6, 2009



1

## A Primer on Financial Engineering

The goal of this presentation is to provide an intuitive explanation of some of the key concepts underlying the current financial crisis, including:

- The three criteria for evaluating all financial instruments
- The role of the rating agencies
- Characteristics of Bonds and Mortgages
- The role of Fannie Mae and Freddie Mac
- Structured instruments and swaps

2

## The 3 Criteria for Evaluating Financial Instruments

- Amount of Cash Flow (more is better)
- Timing of Cash Flow (sooner is better)
- The Probability of Cash Flow (more certain is better)

*Probability* is primarily affected by counterparty credit risk, the risk that the entity that owes you money will fail to pay.

Probability can also be a function of an option component which would typically also affect the amount and possibly timing of the payments, e.g., an option to buy a stock at a price by a certain date.

3

## The 3 Criteria for Evaluating Financial Instruments

A relatively straightforward example would be a \$1,000 United States Treasury Note maturing in 2 years paying 5% interest per year semi-annually.

The **Amount** and **Timing** of the Cash Flows is known:

6 months \$25 (\$1,000 x 5% / 2) interest

12 months \$25 "

18 months \$25 "

24 months \$1,025 (the \$25 semi-annual interest + the \$1,000 principle)

The **Probability** of payment by the USG is considered 100%

4

## Zero Coupon Bonds

**Zero Coupon Bonds** do not pay periodic interest (they have a zero coupon) but only pay principle at maturity.

Zero Coupon bonds sell at a discount to their principle, i.e., if the bond will pay \$1,000 in 2 years it would be worth something less than \$1,000 today, e.g., \$900. The actual value is a function of the prevailing interest rates in the market.

5

## HEADLINE NEWS

**New Technology Will Transform the World!**  
**Everyone wants to invest and get rich quick!**



Transcontinental Railroad, 1869

6

Late 1800s  
Early 1900s

**The Rating Agencies**

In 1860, Henry Varnum Poor publishes *The History of Railroads and Canals in the United States*, a precursor of modern stock reporting and analysis.

John Moody & Company published *Moody's Manual of Industrial and Miscellaneous Securities* in 1900 and *Moody's Analyses of Railroad Investments* in 1909.

John Knowles Fitch founded the Fitch Publishing Company in 1913 which published financial statistics.

These were the beginnings of **Standard & Poor's**, **Moody's** and **Fitch**, currently the three dominant rating agencies.

**The Rating Agencies**

	S&P	Moody's	Fitch
Best Credit Quality	AAA	Aaa	AAA
	AA	Aa	AA
	A	A	A
	BBB	Baa	BBB
	BB	Ba	BB
	B	B	B
	CCC	Caa	CCC
	CC	Ca	CC
	C	C	C
Lowest Credit Quality Defaulted	D	D	D

**The Rating Agencies**

**Rating Agency Key Concept #1**  
Originally, ratings were a rank ordering

**Rating Agency Key Concept #2**  
Originally, Rating Agencies were paid by the investor

HEADLINE NEWS

**Financial Bubble Bursts!**

**Banks Fail**

**No Credit Is Available**

**1930s**

### The Rating Agencies

In the mid-1930s, bank regulators began to require banks to invest only in bonds with an Investment Grade rating from a "recognized rating agency".

In the 1930s and 40s state regulators developed similar requirements for insurance companies.

13

### The Rating Agencies

	S&P	Moody's	Fitch
Investment Grade	AAA	Aaa	AAA
	AA	Aa	AA
	A	A	A
	BBB	Baa	BBB
Non-Investment Grade High Yield Junk	BB	Ba	BB
	B	B	B
	CCC	Caa	CCC
	CC	Ca	CC
	C	C	C
	D	D	D

14

### The Rating Agencies

#### Rating Agency Key Concept #1

Originally, ratings were a rank ordering

#### Rating Agency Key Concept #2

Originally, Rating Agencies were paid by the investor



#### Rating Agency Key Concept #3

Bond issuers needed to have a rating agency rating in order to have their bonds eligible for purchase by two of the largest bond investor groups: banks and insurance companies

15

### Mortgages

Originally, savings and loans and local banks collected deposits and lent the money to borrowers in the form of mortgages to buy homes.



[http://www.youtube.com/watch?v=\\_Er69b4HMI8](http://www.youtube.com/watch?v=_Er69b4HMI8)

16

### FNMA

At the request of FDR, the Federal National Mortgage Association (FNMA or Fannie Mae) was founded in 1938 to provide liquidity for Federal Housing Administration (FHA) guaranteed mortgages.

#### FNMA Key Concept #1

Mortgage Originators are no longer owners of the mortgages.

They do, however, typically keep the servicing. Servicing is typically .25% of the outstanding balance.

17

**Late 1960s -  
Early 1970s**

18

### FNMA, GNMA & FHLMC

In 1968, the Federal Government converted FNMA into a publicly owned corporation, a Government Sponsored Entity (GSE).

The Federal Government also created the *Government National Mortgage Association* (GNMA or Ginnie Mae). GNMA guarantees timely payment of P&I for a fee.

19

### FNMA

#### FNMA Key Concept #1

Mortgage Originators are no longer owners of the mortgages.

They do, however, typically keep the servicing.

#### FNMA Key Concept #2

FNMA is a privately owned for-profit corporation.

#### FNMA Key Concept #3

FNMA is NOT guaranteed by the Federal Government, but as a GSE it is assumed to have an implicit guarantee.

20

### FNMA, GNMA & FHLMC

In 1970, the Federal Government created another GSE, *The Federal Home Loan Corporation* (FHLMC or Freddie Mac) which is similar to FNMA.

In 1970, GNMA issues the first pass through. Groups of mortgages are pooled together and the principle and interest from the mortgages in the pool pass-through to investors. FNMA and FHLMC soon also issue similar pass-throughs all which are generically referred to as *Mortgage Backed Securities* (MBS).

21

### Mortgage Backed Security (MBS)

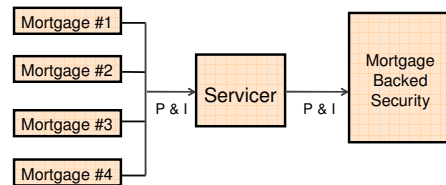

22

### The Rating Agencies

In 1975 the Securities and Exchange Commission (SEC) established capital guidelines for Broker Dealers.

These guidelines were based on the quality of the bonds held by the broker dealers. (Similar to the banks.)

The quality of the bonds would be determined by ratings from **Nationally Recognized Statistical Rating Organizations**. Moody's, S&P and Fitch were grandfathered in.

23

### The Rating Agencies

Pension funds and mutual funds also adopted requirements that only investments rated as Investment Grade by the rating agencies could be held.

24

### The Rating Agencies

#### Rating Agency Key Concept #1

Originally, ratings were a rank ordering

#### Rating Agency Key Concept #2

Originally, Rating Agencies were paid by the investor

#### ➡ Rating Agency Key Concept #3 Updated

Bond issuers needed to have a rating agency rating in order to have their bonds eligible for purchase by ~~two of the largest bond investor groups: banks and insurance companies~~ virtually anyone who is likely to invest in a bond.

25

### The Rating Agencies

#### Rating Agency Key Concept #1

Originally, ratings were a rank ordering

#### ~~Rating Agency Key Concept #2~~

~~Originally, Rating Agencies were paid by the investor~~

#### ➡ Rating Agency Key Concept #2 Updated

Originally, Rating Agencies were paid by the Investor, but are now paid by the Bond Issuer.

#### Rating Agency Key Concept #3 Updated

Bond issuers needed to have a rating agency rating in order to have their bonds eligible for purchase by virtually anyone who is likely to invest in a bond.

26

### Treasury Bond

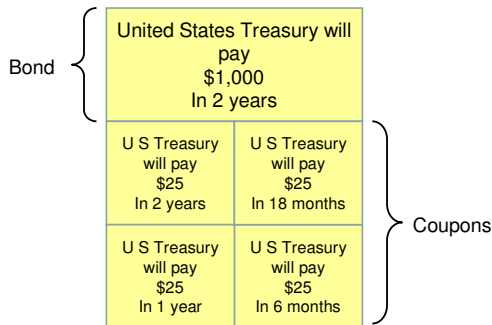

27

### Stripped Treasury Bond

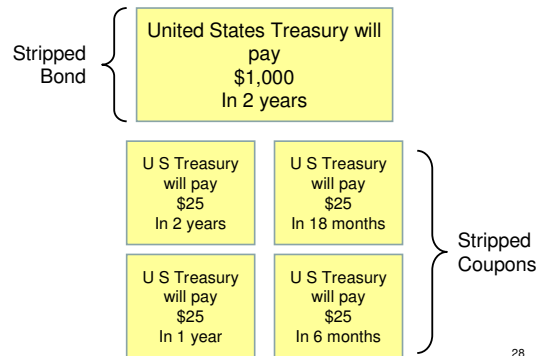

28

### Stripped Treasury Bond

Wall Street firms stripped treasuries by putting them into custodial accounts and selling custodial receipts for each zero coupon to investors.

- Merrill Lynch *Treasury Investment Growth Receipts* (TIGRs)
- Salomon Brothers *Certificates of Accrual on Treasury Securities* (CATS)
- Lehman Brothers *Lehman Investment Opportunities Notes* (LIONS)

29

### Stripped Treasury Bond

#### Stripped Treasuries Key Concept

The sum of the values of the strips  $>$  the value of the Treasury Bond

Wall Street stopped issuing stripped treasuries when the Treasury began issuing their own version:

- *Separate Trading of Registered Interest and Principal of Securities* (STRIPS)

30

# 1980s

## Mortgages

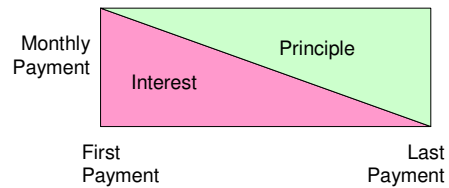

Mortgage loans are a form of borrowing secured by real estate. A standard mortgage is an annuity whereby the borrower makes fixed monthly payments such that principle and interest are paid off by the last payment.

32

## Mortgages

**Mortgage Key Concept #1**  
Payments are a combination of interest and principle

**Mortgage Key Concept #2**  
The proportion of interest to principle decreases from one payment to the next

33

## Mortgage IOs and POs

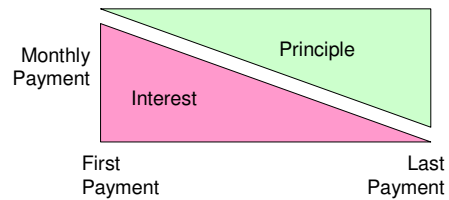

Financial firms stripped the interest and principle on mortgage backed securities and sold them separately as *Interest Only (IO)* and *Principle Only (PO)* securities.

34

## Mortgage IOs and POs

When homeowners pay off their mortgages early, the owner of the *Principle Only* gets paid back quicker....

But the owner of the *Interest Only* no longer gets paid.

35

## Mortgages

**Mortgage Key Concept #1**  
Payments are a combination of interest and principle

**Mortgage Key Concept #2**  
The proportion of interest to principle decreases from one payment to the next

➡ **Mortgage Key Concept #3**  
Homeowners can pay off mortgages early. These prepayments make cash flows uncertain for investors. Therefore, the estimate for prepayment speed is critical to valuing mortgage investments.

36

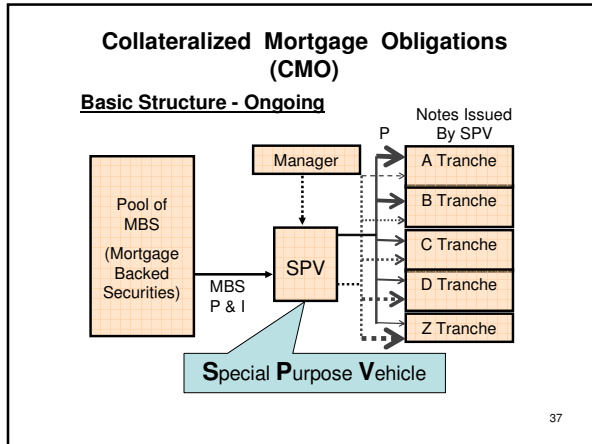

### Collateralized Mortgage Obligations (CMO)

By directing the payment of Principle and Interest to the individual tranches, the CMO creates a series of different bonds with more predictable cash flows.

**CMO Key Concept #1**

The sum of the values of the tranches  $>$  the value of the MBS

38

### Turning Straw Into Gold

- Credit Card Receivables
- Car Loans
- Boat Loans
- Student Loans

39

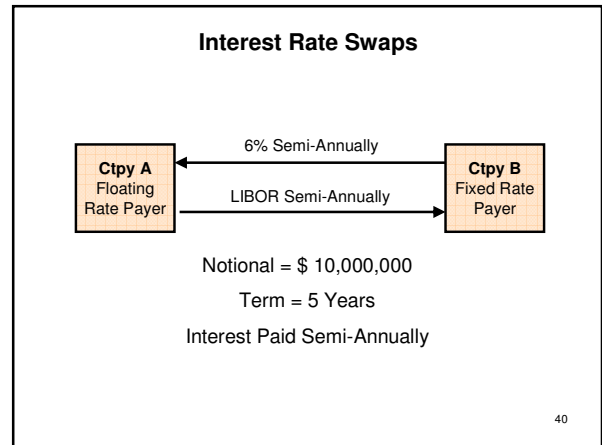

### Cherry Picking

Cherry picking is the process in bankruptcy whereby the amounts owed to the defaulting company are collected in full from each outside entity and the amounts owed by the defaulting company to all outside entities are pooled and paid a proportional share.

41

### Cherry Picking

In this example, you might think that you are even with the bankrupt company.

However, you would be expected to pay the \$100 you owe and then be paid back a proportion of the \$100 they owe you, e.g., 10 cents on the dollar.

42

### ISDA

In 1985 the *International Swaps Dealers Association (ISDA)* was formed. Over time they successfully lobbied to amend bankruptcy law in all major global financial markets to allow netting of swap transactions, i.e. cherry picking was eliminated for transactions documented as a swap.

In the prior example, with netting you would owe nothing to the bankrupt company.

Eventually, ISDA changed their name to the *International Swaps and Derivatives Association*.

43

### Cross Currency (FX) Swap

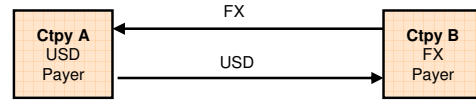

USD Notional = \$ 10,000,000

FX Notional = FX 7,000,000

Term = 5 Years

Interest Paid Semi-Annually

Notional Paid At Maturity

44

### Equity Swap

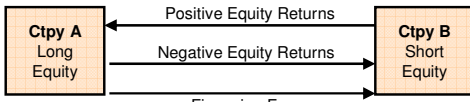

USD Notional = \$ 10,000,000

Equity = 10,000 Shares NE Co.

Term = 5 Years

Interest Paid Semi-Annually

Equity Returns Paid Semi-Annually

45

### Insurance Swap

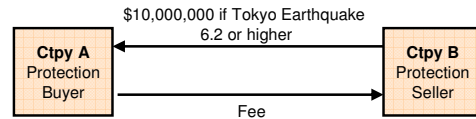

USD Notional = \$ 10,000,000

Term = 5 Years

46

### Derivative Embedded In A Bond

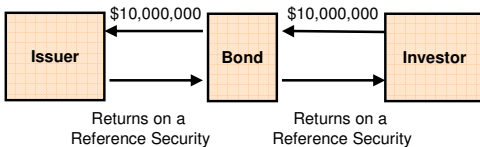

47

1990s



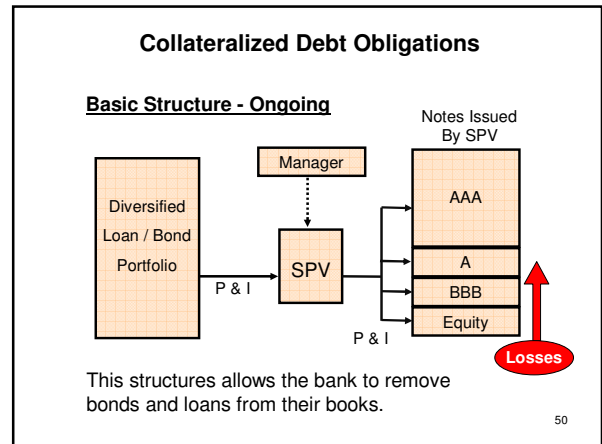
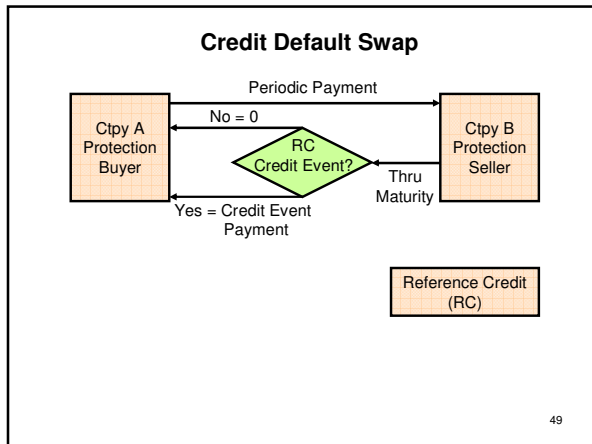

### The Rating Agencies

~~**Rating Agency-Key Concept #1**  
Originally, ratings were a rank ordering~~

➡ **Rating Agency Key Concept #1 Updated**  
Originally, ratings were a rank ordering, but structured product ratings are based on statistical models.

**Rating Agency Key Concept #2 Updated**  
Originally, Rating Agencies were paid by the Investor, but are now paid by the Issuer.

**Rating Agency Key Concept #3 Updated**  
Bond issuers needed to have a rating agency rating in order to have their bonds eligible for purchase by virtually anyone who is likely to invest in a bond.

51

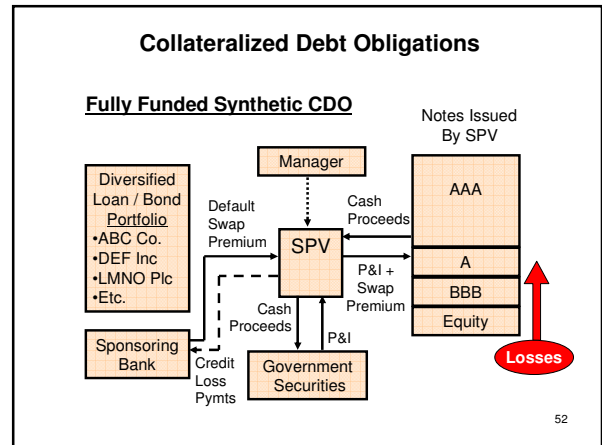

### Collateralized Debt Obligations

#### Fully Funded Synthetic CDO

This structure uses credit default swaps to transfer the risk of the portfolio to the SPV without having to actually sell the securities.

This structure also uses the technique of investing the cash proceeds into low-risk securities, typically US treasury strips.

53

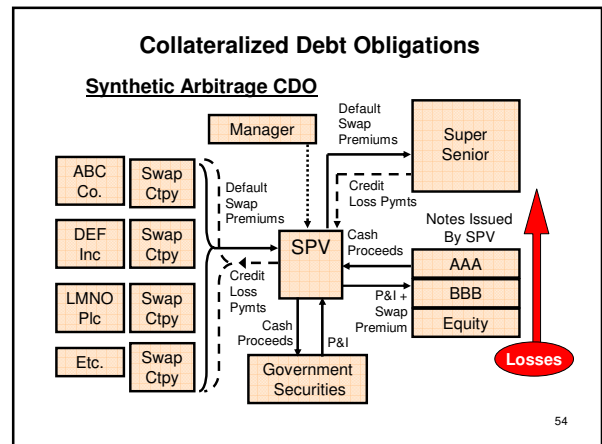

## Collateralized Debt Obligations

### Synthetic Arbitrage CDO

This structure uses credit default swaps to synthetically create a portfolio. It is no longer necessary to purchase securities from, e.g., ABC Co or DEF Inc or LMNO Plc, as long as you can gain exposure to their risk through a credit default swap.

55

2000s

## Collateralized Debt Obligations

### Synthetic Re-Securitization

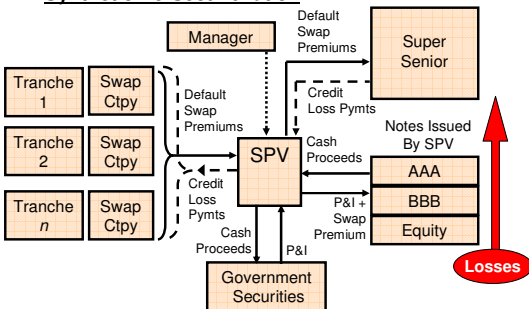

57

## Collateralized Debt Obligations

### Synthetic Re-Securitization

This structure takes tranches from already structured CDOs and reuses them as raw material for a new CDO, thus they "re-securitizes" them.

## A Final Thought

In 1988, central bankers from around the world approved the Basel Accord, which set guidelines for bank capital requirements. This accord has been adopted by the G-10 countries including the United State.

These regulations are universally considered inadequate and in 2004, the Basel II Accord was proposed.

59

## A Final Thought

A key provision of Basel II is that banks can use their internal risk models to set their regulatory capital.

This is based on the assumption that banks have the best models to evaluate their own risks better than anyone else.

And the calculations are heavily dependent on ratings from rating agencies.

60